

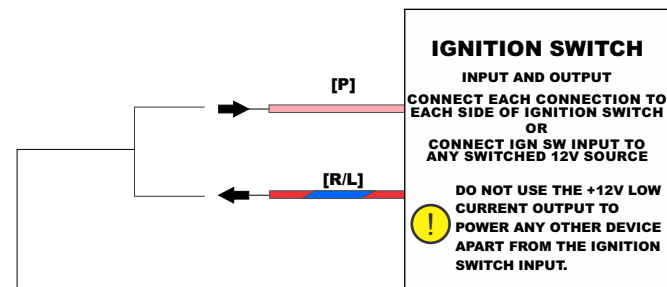

HT-183200 UNIVERSAL WIRE-IN HARNESS FOR NEXUS R3 VCU

NOTES

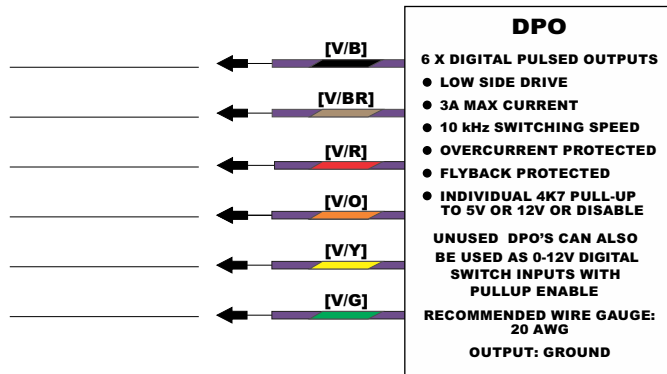
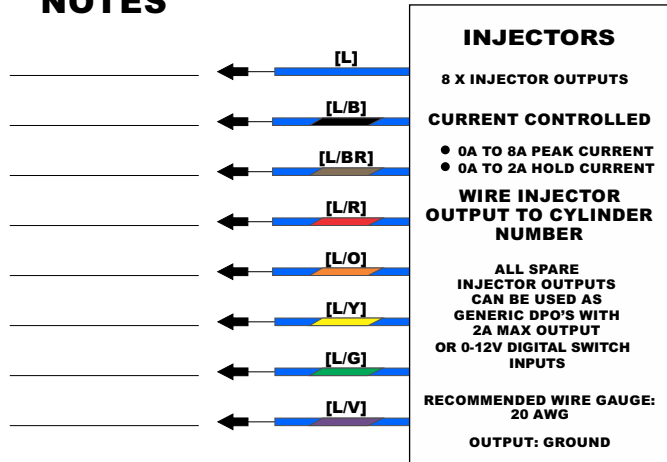

SWITCHING THE NEXUS R3 VCU ON
METHOD 1 - CONNECTING TO EXISTING IGNITION KEY SWITCH WIRING

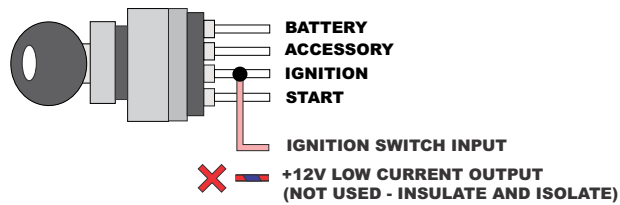

SWITCHING THE NEXUS R3 VCU ON
METHOD 2 - USING A GENERIC TOGGLE SWITCH

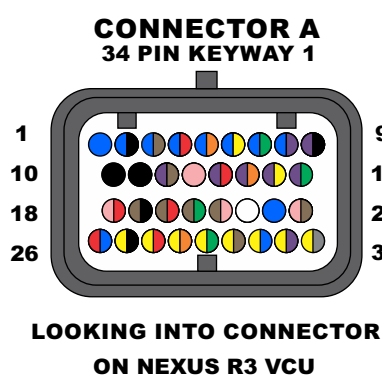
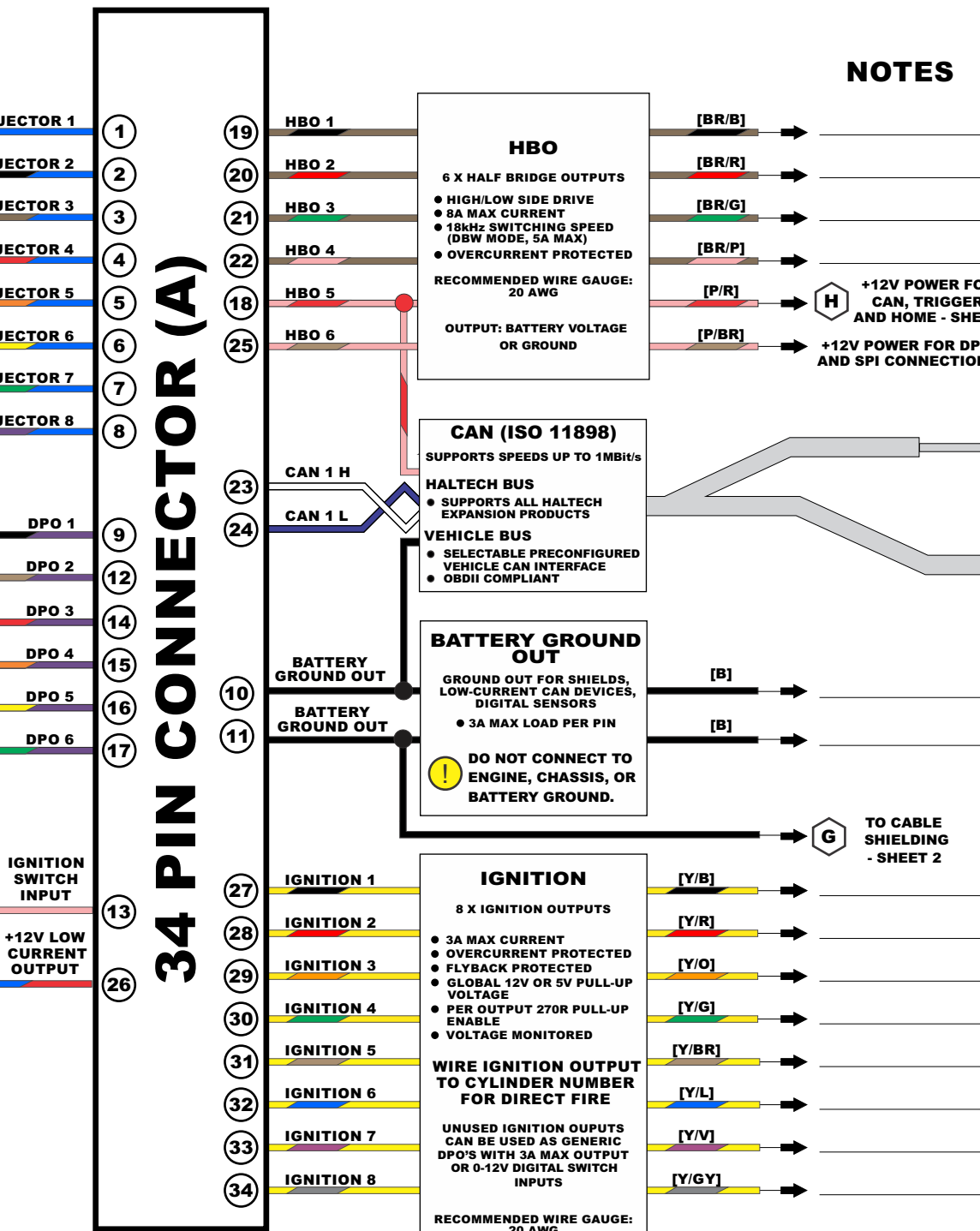
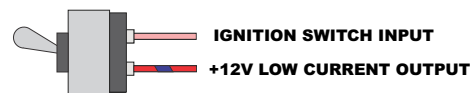

NOTES

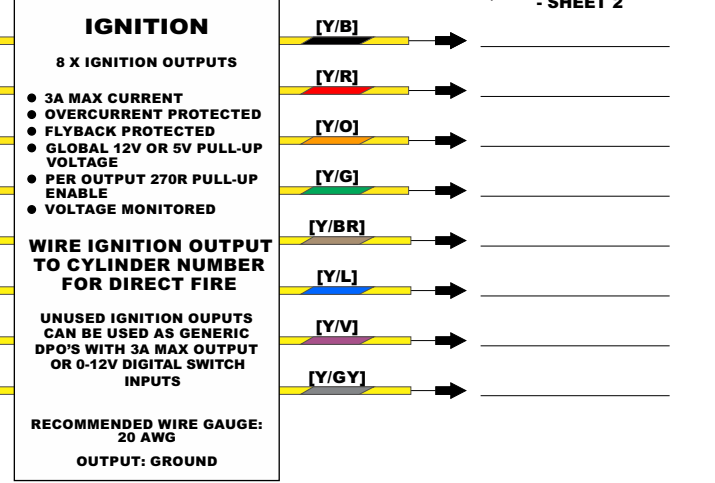
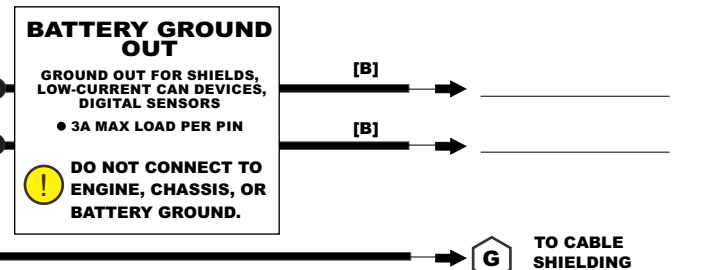
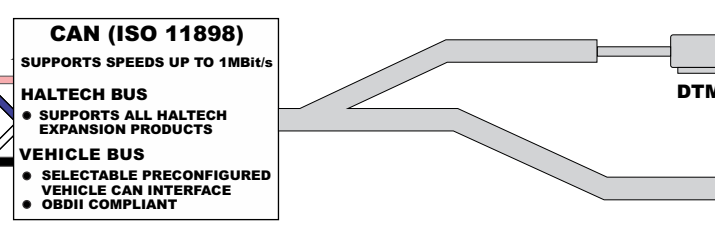
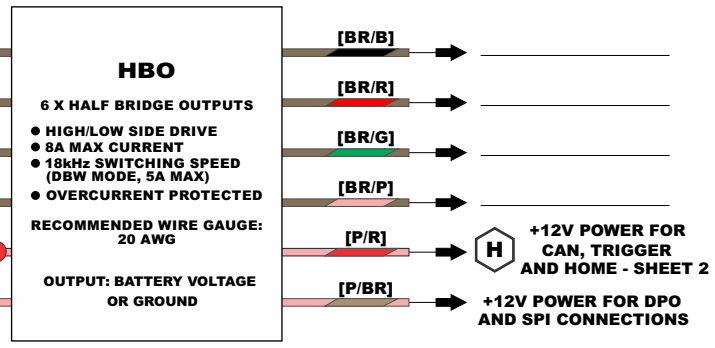

WARNING!
THIS HARNESS DOES NOT GROUND YOUR ENGINE. MAKE SURE THE ENGINE IS SUFFICIENTLY GROUNDED USING A GROUND / EARTHING STRAP TO THE BATTERY. KEEP ALL WIRES AWAY FROM THE EXHAUST MANIFOLD.

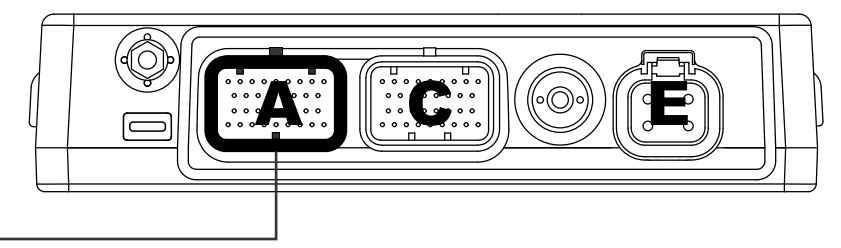
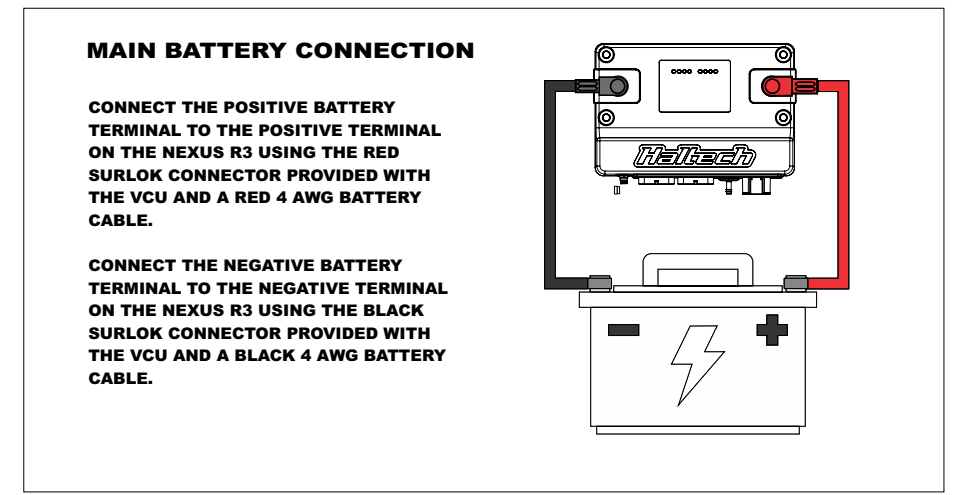
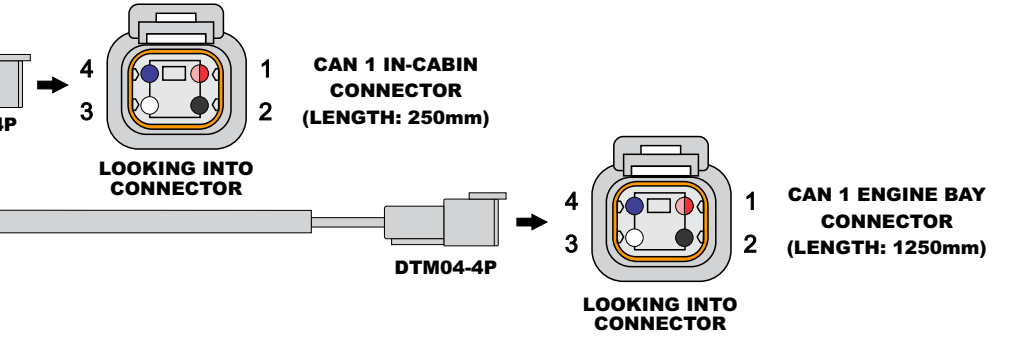

LEGEND - WIRE COLOUR
B = BLACK BR = BROWN G = GREEN GY = GREY L = BLUE
LL = LIGHT BLUE LG = LIGHT GREEN LY = LIGHT YELLOW O = ORANGE
P = PINK R = RED V = VIOLET Y = YELLOW W = WHITE
WHEN TWO COLOURS ARE USED IN A WIRE BY THE ALPHABETICAL CODE, THE FIRST LETTER INDICATES THE BASIC WIRE COLOUR, THE SECOND COLOUR INDICATES THE COLOUR OF THE STRIPE.

Haltech	
HT-183200 UNIVERSAL WIRE-IN HARNESS FOR NEXUS R3 VCU - WIRING DIAGRAM	
DOCUMENT REVISION: 1.0	HARNESS REVISION: C
DATE: JANUARY 2023	SHEET 1 OF 2



HT-183200 UNIVERSAL WIRE-IN HARNESS FOR NEXUS R3 VCU

NOTES

TRIGGER AND HOME INPUTS

- SUPPORTS RELUCTOR INPUTS
- SUPPORTS DIGITAL INPUTS
- SELECTABLE GROUND REFERENCE AND PULLUP TO 5V
- 48kHz MAX SIGNAL FREQUENCY

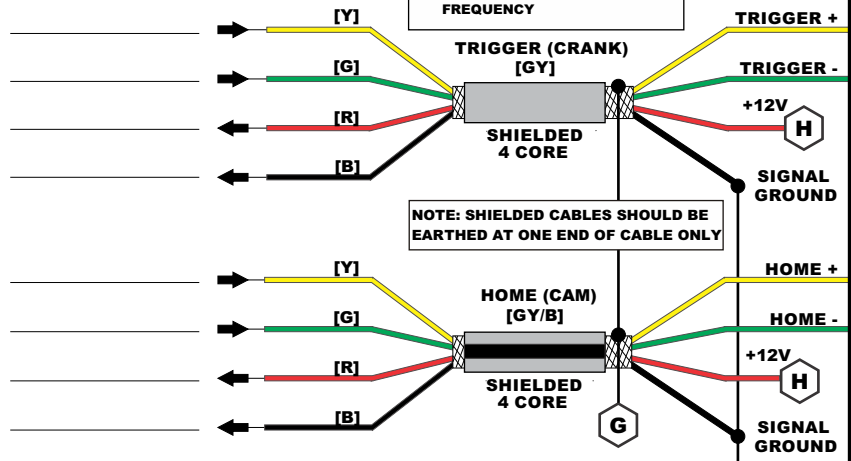

NOTE: SHIELDED CABLES SHOULD BE EARTHED AT ONE END OF CABLE ONLY

SPI

6 X SYNCHRONISED PULSED INPUTS

- SUPPORTS RELUCTOR INPUTS
- SUPPORTS DIGITAL INPUTS
- SUPPORTS 0-5V ANALOG INPUTS
- 22.5kHz MAX FREQUENCY
- 25V MAX INPUT VOLTAGE
- SWITCHABLE 1K PULL-UP

RECOMMENDED WIRE GAUGE: 22 AWG

MEASUREMENT RANGE: -10V TO 10V

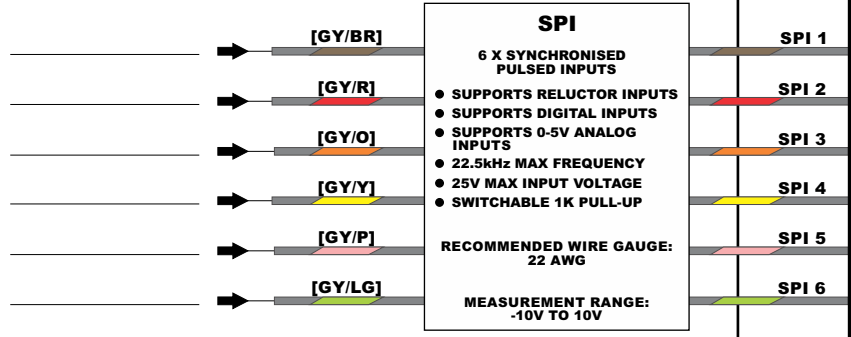

SIGNAL GROUND

- 500mA MAX OUTPUT CURRENT

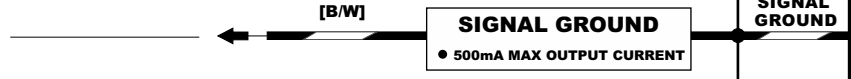

SHIELDED 2 CORE [B/L]

NOTE: SHIELDED CABLES SHOULD BE EARTHED AT ONE END OF CABLE ONLY

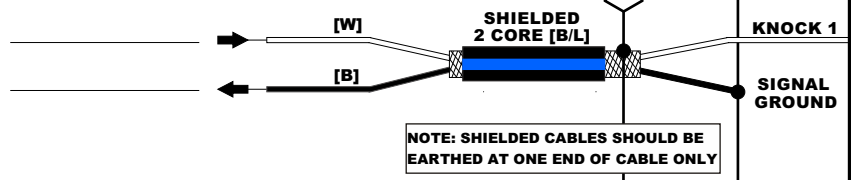

SHIELDED 2 CORE [B/G]

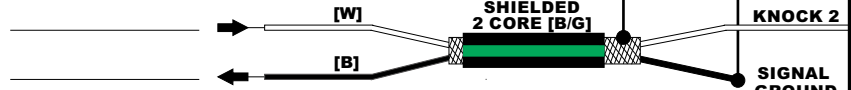

KNOCK INPUTS

- -2.5V TO +2.5V AC INPUT ONLY
- 160Hz TO 48kHz SIGNAL FREQUENCY

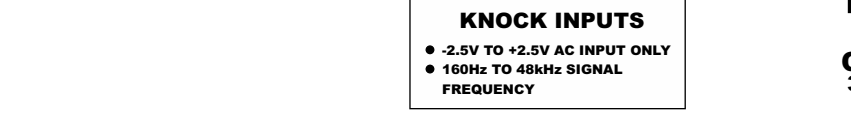

LEGEND - CONNECTION POINTS

G CONNECTION TO BATTERY GROUND OUTPUT ON CONNECTOR A - SHEET 1

H CONNECTION TO HBO 5 (+12V) - SHEET 1

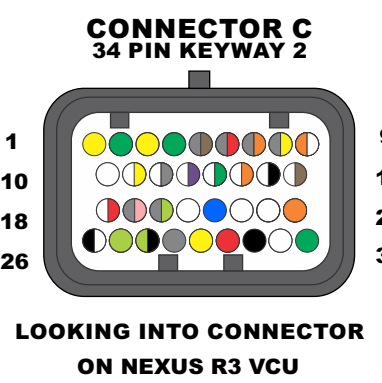
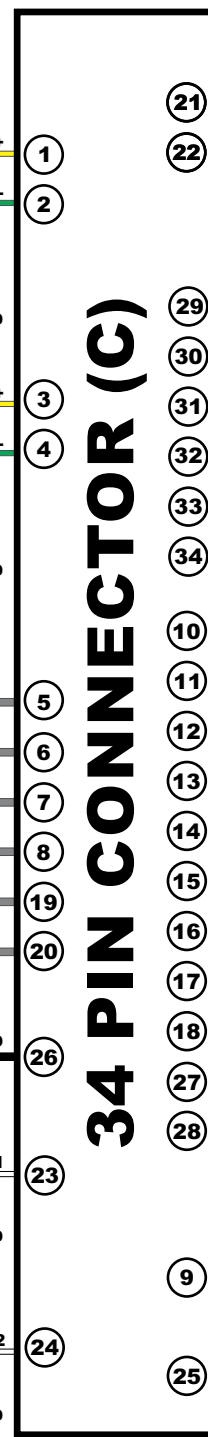

CAN (ISO 11898)

SUPPORTS SPEEDS UP TO 1MBit/s

HALTECH BUS

- SUPPORTS ALL HALTECH EXPANSION PRODUCTS

VEHICLE BUS

- SELECTABLE PRECONFIGURED VEHICLE CAN INTERFACE
- OBDII COMPLIANT

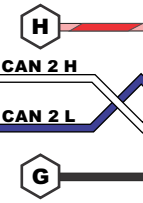

WIDEBAND SENSOR INPUT

COMPATIBLE WITH BOSCH LSU 4.9 AND NTK SENSORS

SELECT WHICH SENSOR IS BEING USED IN THE NSP SOFTWARE

- COMPATIBLE WITH ETHANOL
- MUST BE INSTALLED PRE CATALYTIC CONVERTOR
- OPTIONAL WIDEBAND HARDWARE PACK MAY BE PURCHASED IF REQUIRED (HT-010746 FOR LSU4.9) (HT-010747 FOR NTK)

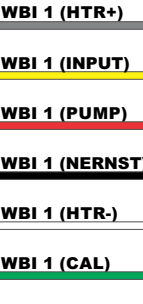

AVI

11 X ANALOG VOLTAGE INPUTS

- INDIVIDUAL SOFTWARE SELECTABLE 1K PULL-UP TO 5V
- USER DEFINABLE INPUTS CAN BE ALLOCATED TO AVAILABLE FUNCTIONS IN THE SOFTWARE
- 30V MAX INPUT VOLTAGE
- 1000 SAMPLES/SECOND
- 1.5kHz MAX INPUT FREQUENCY
- ALL AVIS CAN BE USED FOR NARROWBAND O2 AND DBW INPUTS

RECOMMENDED WIRE GAUGE: 22 AWG

INPUT: -10V TO 30V

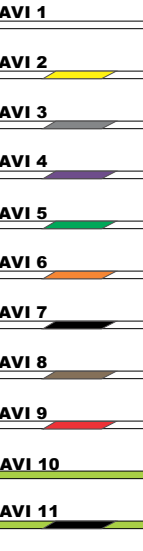

+8V SENSOR SUPPLY

- 200mA MAX OUTPUT CURRENT



+5V SENSOR SUPPLY

- 200mA MAX OUTPUT CURRENT



NOTES

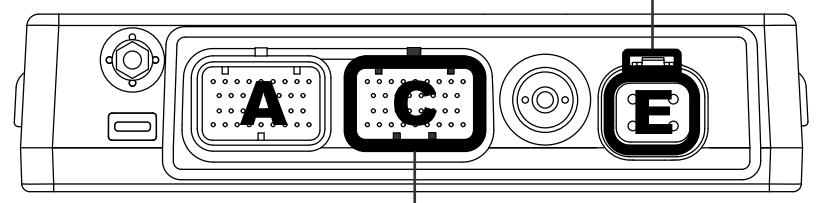
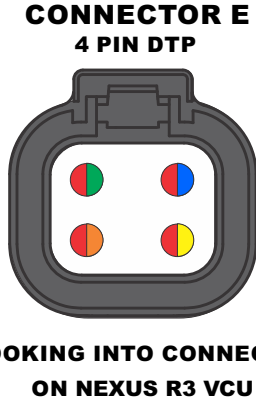
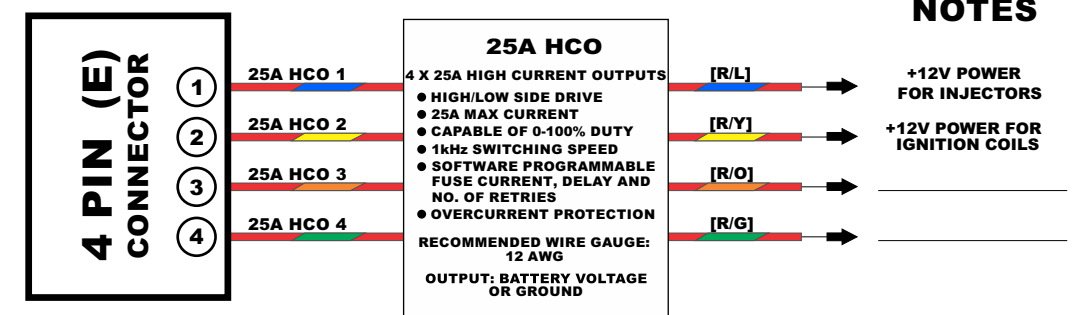
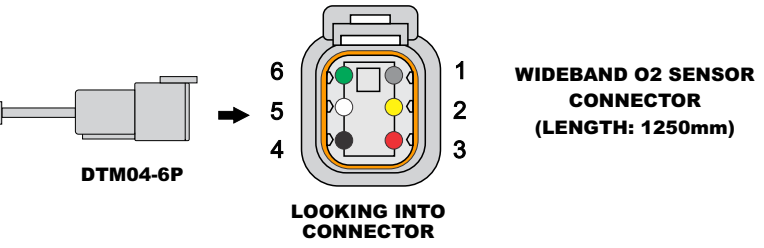
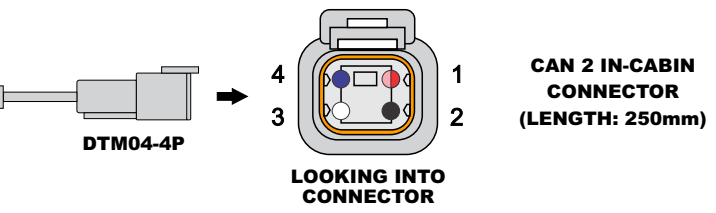

LEGEND - WIRE COLOUR

B = BLACK BR = BROWN G = GREEN GY = GREY L = BLUE LL = LIGHT BLUE LG = LIGHT GREEN LY = LIGHT YELLOW O = ORANGE P = PINK R = RED V = VIOLET Y = YELLOW W = WHITE

WHEN TWO COLOURS ARE USED IN A WIRE BY THE ALPHABETICAL CODE, THE FIRST LETTER INDICATES THE BASIC WIRE COLOUR, THE SECOND COLOUR INDICATES THE COLOUR OF THE STRIPE.