

Haltech

NEXUS PD16

QUICK START GUIDE

NEXUS PD16 OVERVIEW

The NEXUS PD16 is Haltech's new power distribution product. Boasting new, innovative yet user-friendly technology, it sets a new market standard for power distribution systems.

Designed to integrate seamlessly into your existing Haltech Elite or Nexus engine management system, the PD16 ensures safe, dependable power delivery to your vehicle.

Features

- 10 x 8A High Side Outputs
- 2 x 8A Half Bridge Outputs
- 4 x 25A High Current Outputs
- 8 x Inputs + Dedicated Ignition Switch Input
- Power for Ignition Switch
- Integrated into Haltech CAN Bus Network
- 5V Sensor Supply / Sensor Ground
- 120A Surlock Connector



2

NEX-US [noun]

- a connection or series of connections linking two or more things.
- a connected group or series
- the central or most important point or place

Optional Accessories (sold separately)

- 5m Flying Lead Harness. HT-188000
- PD16 Tube Mount Kit 1.25" HT-039080
- PD16 Tube Mount Kitt 1.625" HT-039082
- Plug and Pins Set, 34-Pin Keyway 1. HT-030009
- Plug and Pins Set, DTP06-4s, Black 25A. HT-031201
- Replacement 120A Red Surlock Connector. HT-030032
- Hydraulic Cable Lug Crimping Tool. HT-070306

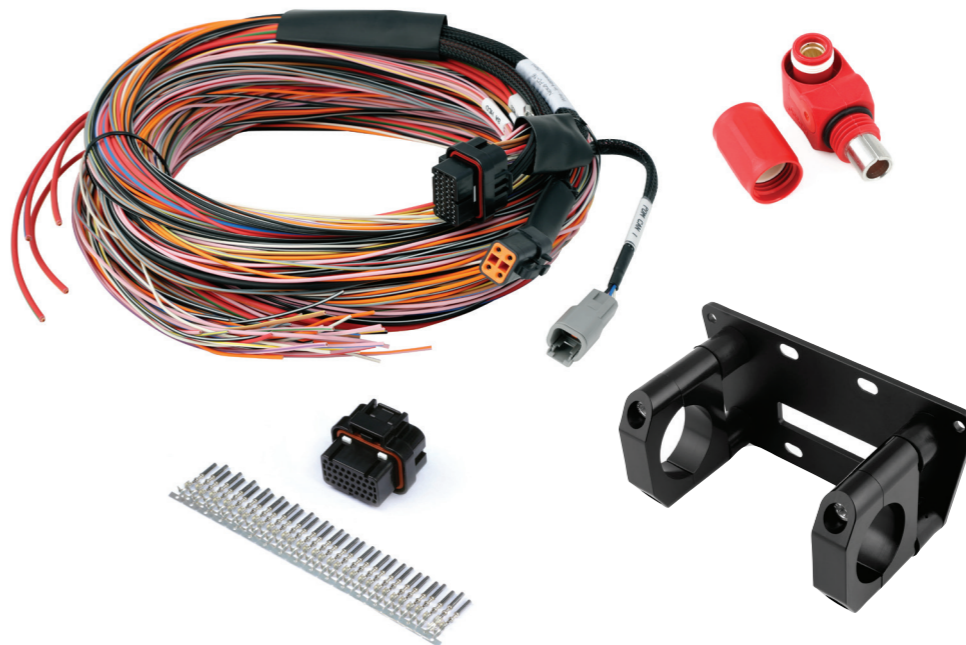

3

NEXUS PD16 OVERVIEW

What's in the box?

- Nexus PD16 Power Distribution Module
- 1 x SurLok Connector (Red) 120A
- USB-C Dust Cap
- Quick Start Guide
- USB-C Cable
- Mounting Hardware (2 x Bolts / Nuts)
- Quick Start Guide
- Haltech Product Catalogue



NEXUS PD16 OVERVIEW

- 1 Power LED
- 2 DTC LED
- 3 WiFi LED
- 4 25A HCO LEDs
- 5 8A HBO LEDs
- 6 8A HCO LEDs
- 7 Battery Positive Stud
- 8 USB-C Port (Firmware update only)
- 9 Superseal 34-pin Connector
- 10 DTP4 Connector
- 11 Mounting Holes

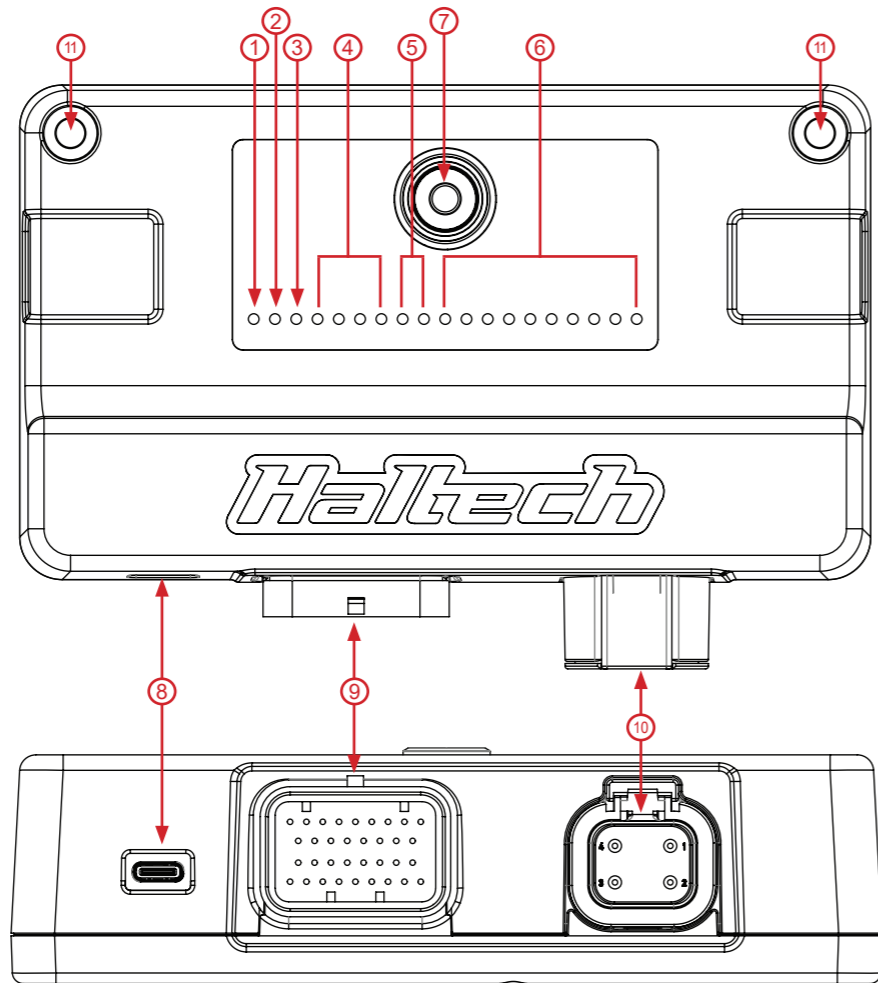

NEXUS PD16 SPECIFICATIONS

OUTPUTS	
Power for Ignition Switch	1
Half Bridge Outputs (HBO)	2
8A High Current Outputs (8A HCO)	10
25A High Current Outputs (25A HCO)	4
INPUTS	
Analog Voltage Inputs (AVI)	4
Synchronised Pulsed Inputs (SPI)	4
Ignition Switch Input	1
OTHER	
5V Sensor Supply	1
Sensor Ground	1
COMMUNICATIONS	
CAN Bus Network 1000 kbit/s	1
Full Speed USB (Firmware upgrade only)	1
ELECTRICAL	
Power Supply (across power terminals)	8 to 20V
No output static current draw	<200mA
Low Power Mode (USB)	4 to 5.5V
Static current draw from USB port	100mA
SurLok Connector Rating	120A (85°C) with 25sqmm (4 AWG)



DIMENSIONS	
Enclosure (Not including connector protrusion)	160 x 42 x 93.5 mm (6.3 x 1.7 x 3.7 in)
Overall (Including connector protrusion)	160 x 42 x 110 mm (6.3 x 1.7 x 4.3 in)
Weight	0.49 kg (1.080 lb)
Operating Temperature (external)	-40 to 85°C (-40 to 185°F)
Onboard Temperature Sensing Zones	5

NEXUS PD16 INSTALLATION

Installing the software

1. Go to the Haltech website (www.haltech.com), navigate to the 'Downloads' section, and click on the download link.

NOTE: You must have the latest version of NSP loaded on your computer.

2. Once the download is complete, locate the downloaded file (usually in the 'Downloads' folder of your computer) and double-click on the file to run the Nexus Software Setup Wizard.

3. Once the Haltech NSP software is installed, connect your laptop to the ECU via a USB cable, and your ECU to the PD16 via a Haltech CAN cable and run the software (see Diagram 1).

4. The latest version of NSP will recognise the PDM automatically. You will see PD16 listed in the main menu tree (see Diagram 2).

5. Enable the PD16 in the Haltech CAN System setup page.

6. You are now ready to configure your PD16 connections in Input/Output menu (see Diagram 3).

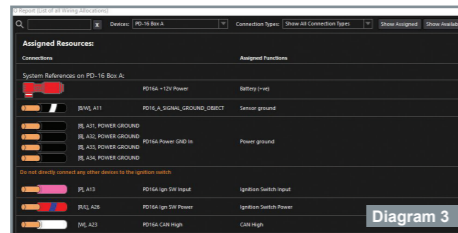
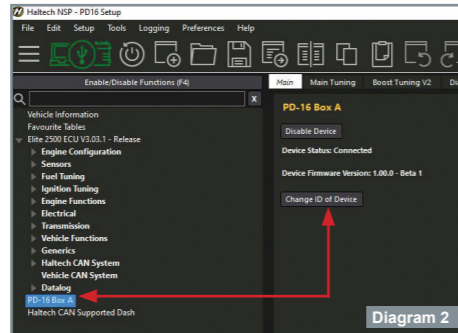
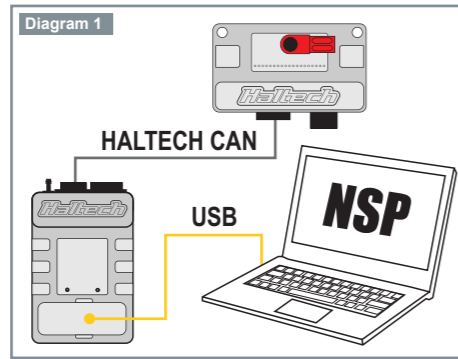

Installing the PD16

There are several ways of installing a PD16 into your system.

The installation method will depend on whether you are wiring it into an existing system and using the PD16 to power your ECU, or using the PD16 as a peripheral power supply with an Elite or Nexus VCU.

We have provided diagrams for the most common types of installations. They are meant to be used as guides only as all installations are different and specific to the car/engine/existing wiring.

It's always a good idea to consult a qualified auto electrician before attempting to install any engine management components, especially if this is your first installation.

Wiring the PD16

To function correctly, the Haltech Nexus PD16 must be connected to battery positive and battery negative at all times. It's important to use correct gauge cables when connecting the Nexus PD16 to the battery terminals.

Connect the Nexus PD16 to the positive battery terminal via the supplied RED SurLok connector using 4AWG cable.

Connect the Nexus PD16 to the negative battery terminal via 18AWG wire(s) on Connector A - Pins 31, 32, 33 and 34.

There are two possible modes of operation; "Master Power Mode" and "Peripheral Power Mode". The key difference is in the function of the A25 CAN 12V pin. In the Master mode, the PD16 powers first, triggering the PDM to provide 12V to Pin A25 to power the CAN bus. In Peripheral mode, the Nexus VCU provides 12V to Pin A25, thus powering up the PD16 after.

Master Power Mode

In this mode the PD16 controls the main power supply to the ECU (common on Elite ECU applications).

Ensure PD16 has battery power and ground. The ignition switch can be a simple switch connecting Pins A13 (Ign. Switch Input) and A26 (Low Current Constant 12V) together. This will power the PD16 once the switch is closed.

NOTE: Ensure there are no other connections to Pins A13 and A26.

In this mode, the PD16 will provide 12V to the CAN bus network via Pin A25 (HCO1) as shown in the diagram on page 10.

This can be used to power an Elite ECU. If the installation has a switched positive signal (from an OE Ignition Switch), it can be connected directly to A13 (Ign. Switch Input).

Pin A26 (Low Current Constant 12V) can be removed from the harness in this scenario.

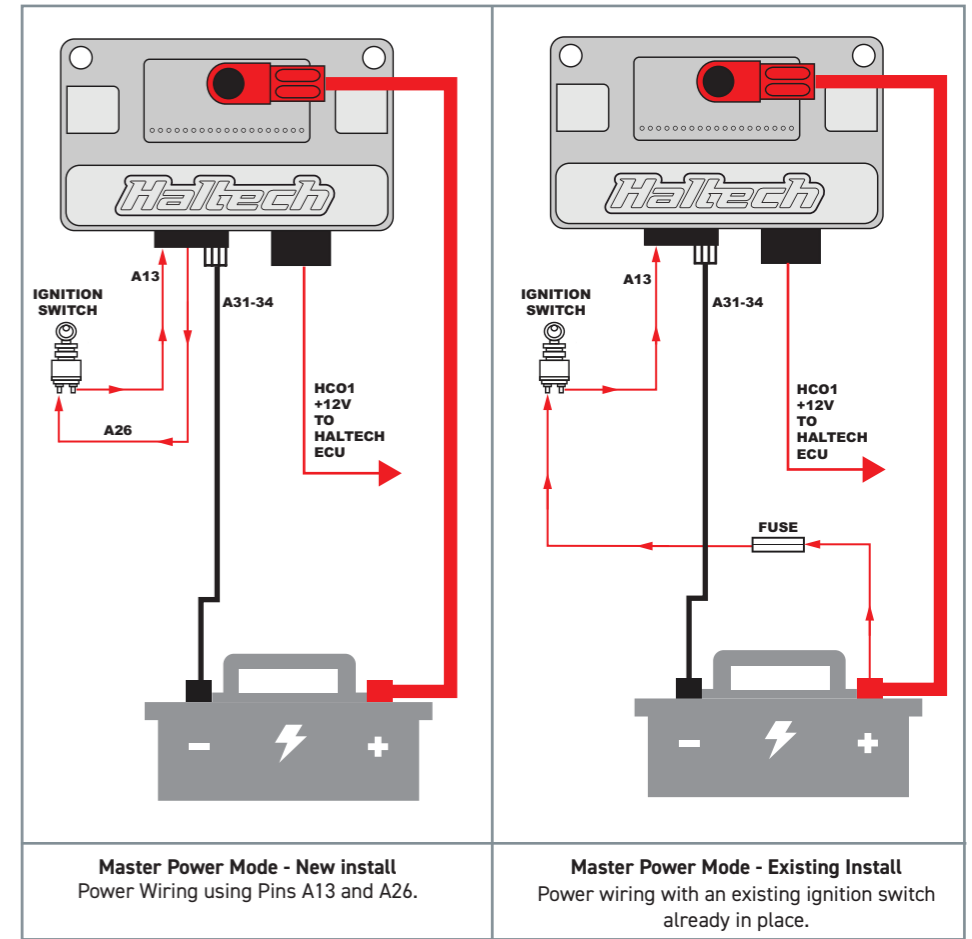

MOUNTING TEMPLATE

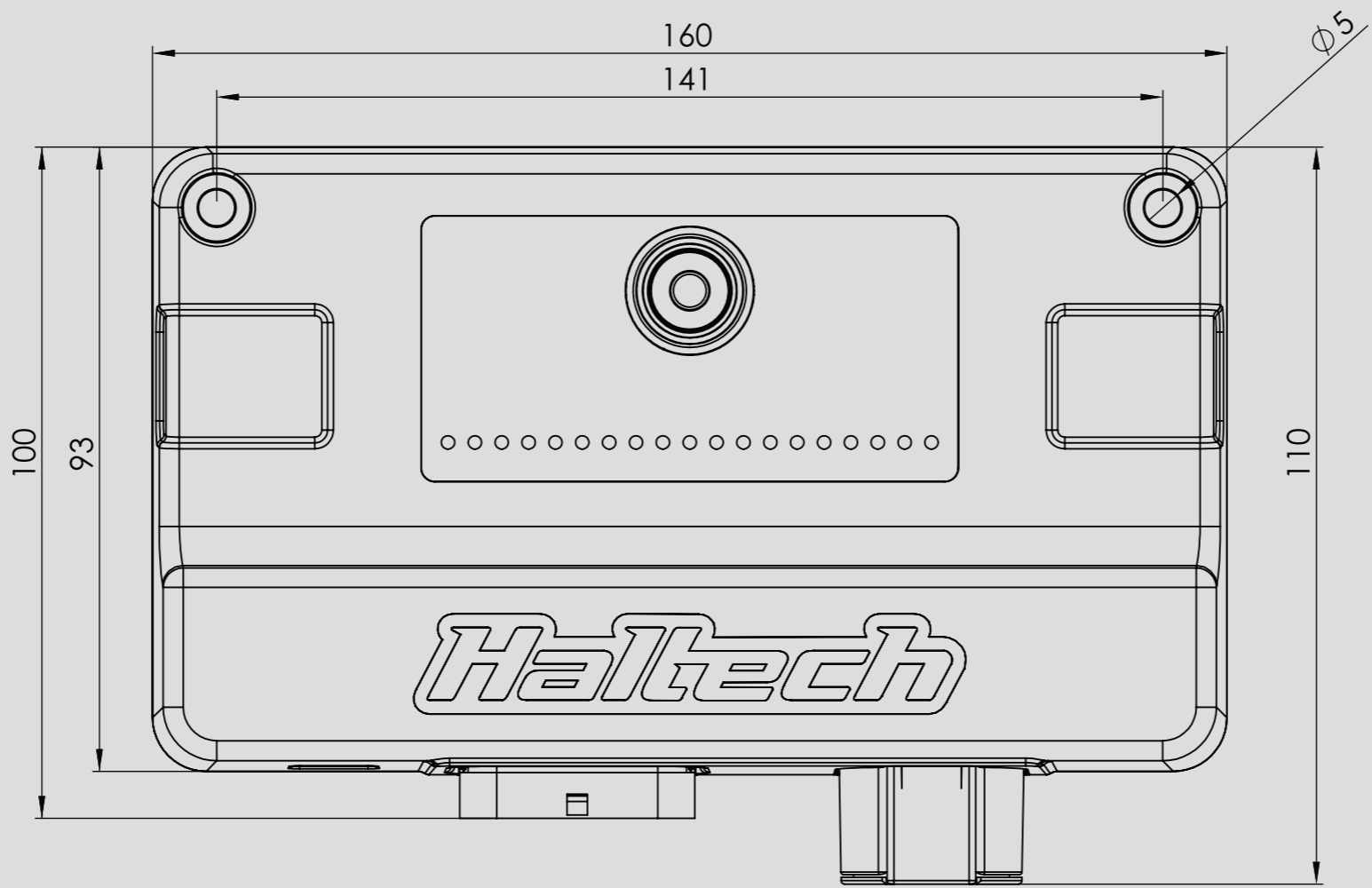

MOUNTING TEMPLATE

NEXUS PD16 WIRING

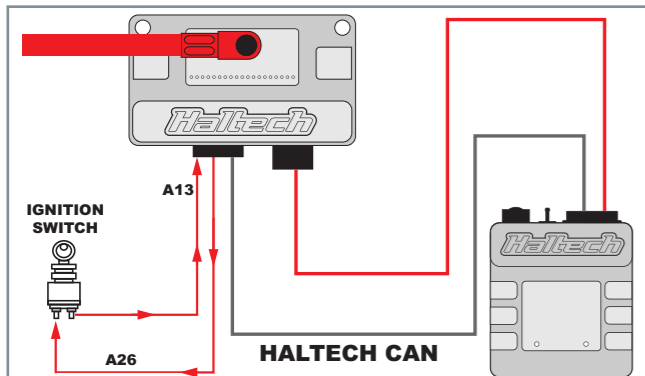

Elite 550,750,950,VMS (Single Connector) wiring in "Master Power" Mode.

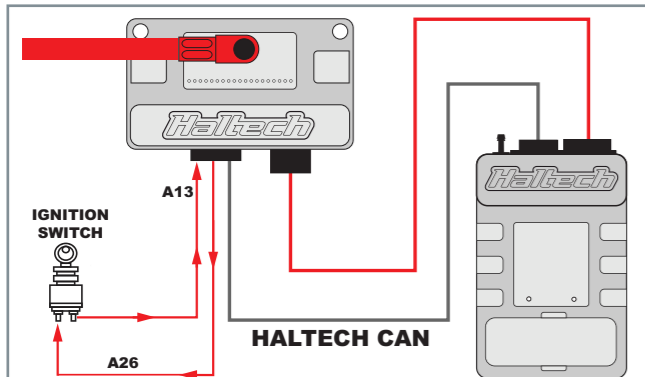

Elite 1000,1500,2000,2500 (Twin Connector) wiring in "Master Power" Mode.

Refer to PD16 Wiring Diagram for more details wiring instructions.

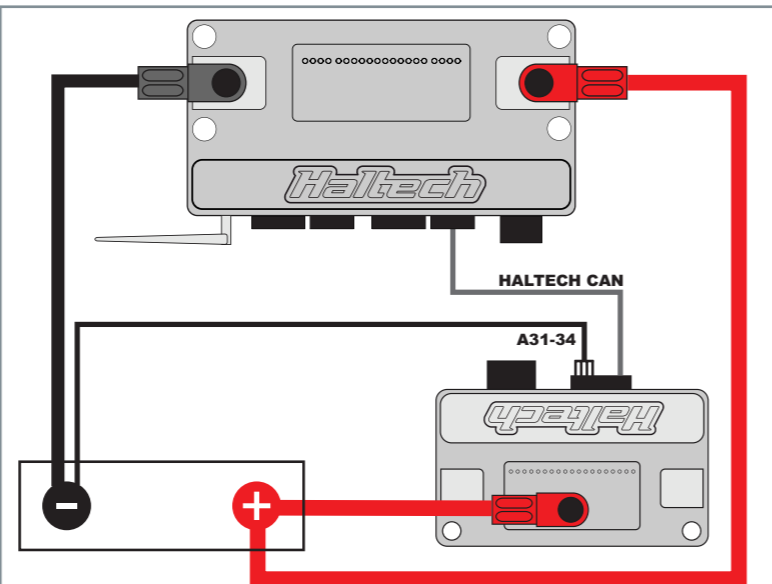

Peripheral Power Mode (Voltage Sense)

In this mode the PD16 acts as a peripheral device to provide the ECU additional I/O (common on Nexus VCU applications). The PD16 is switched on and off via CAN power connection.

Ensure PD16 has battery power and ground. The ignition switch will be ignored, meaning pins A13 (Ign. Switch

Input) and A26 (Low Current Constant 12V) will not be used.

Connect the CAN power output from your ECU or VCU directly to Pin A25 (CAN +12V "Wake-Up") on the PD16.

This can be done using a standard Haltech CAN cable as shown in the diagram above.

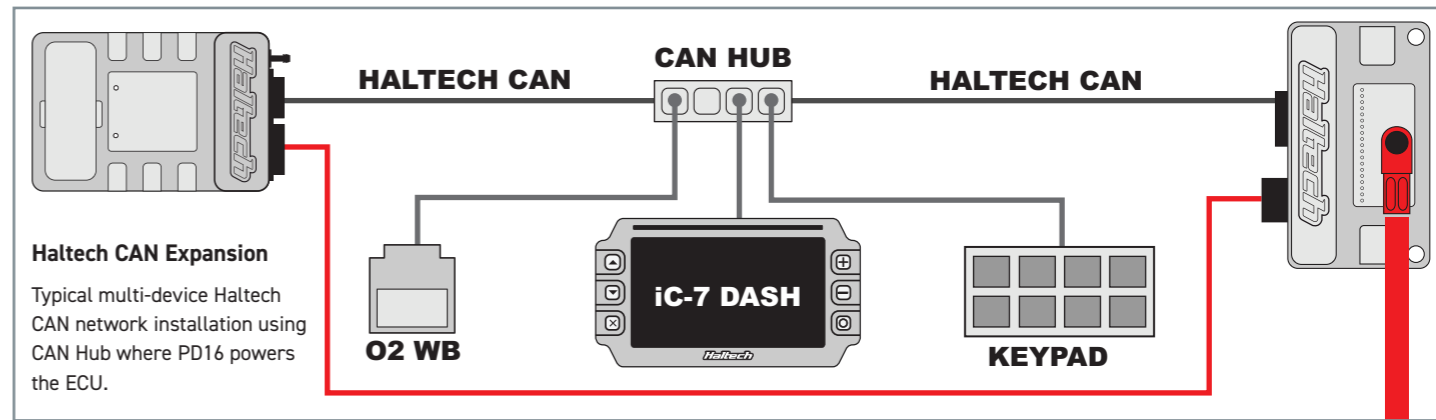

Haltech CAN Expansion

Typical multi-device Haltech CAN network installation using CAN Hub where PD16 powers the ECU.

Half Bridge Outputs (HBO)

Half Bridge Outputs are push-pull, pulse width modulated (PWM) outputs. If not being used as push-pull drivers, Half Bridge Outputs can be used as generic high/low PWM outputs capable of sinking 8A to ground and driving 8A to 12V up to 2.2kHz.

HBOs can be used to control any push-pull type device when used as generic high/low switched or PWM outputs.

Half Bridge Outputs can be used as generic low-side DPOs or to control devices such as high-side driven solenoids, high side switched automatic transmission solenoids, etc.

Specs:

- Overcurrent and Overtemperature Protection
- 0 to 27V voltage feedback
- High side current feedback
- Capable of 0-100% duty cycle
- 2.2kHz switching speed

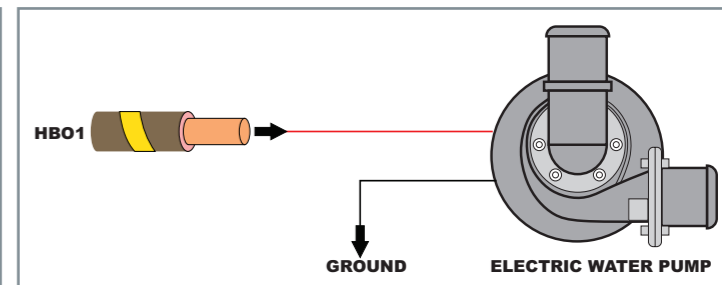
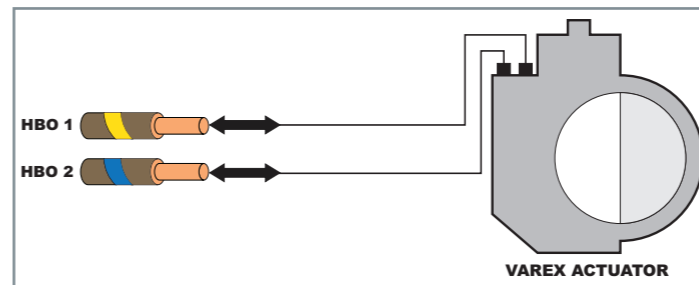

NEXUS PD16 WIRING

8A High Current Outputs (8A HCO)

The Nexus PD16 features 10 high side outputs capable of driving 8A to 12V. Each output has a software programmable fuse current.

Once the electronic fuse blows the output turns off for a software programmable delay duration, before reactivating the output.

Use the NSP software to define the maximum number of retries before the output is deactivated until the next power cycle. The PD16 LEDs display the output state.

8A HCOs are PWM capable and can be used to power CAN devices or solenoids as well as transmission shift solenoids, water pumps, etc.

Example 8A HCO Wiring Connections

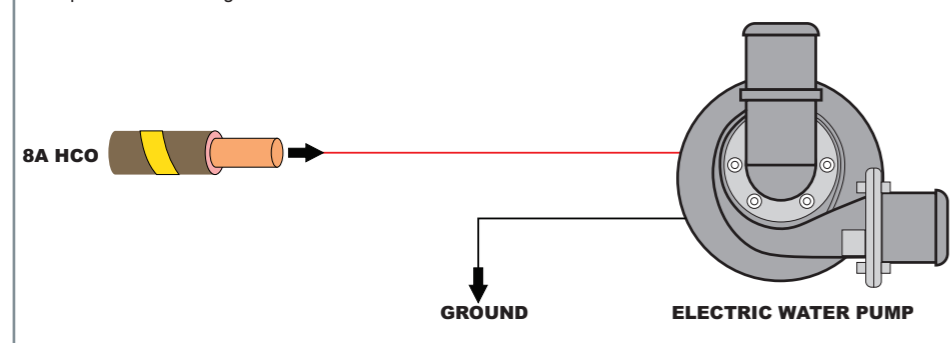

Example 25A HCO Wiring Connections

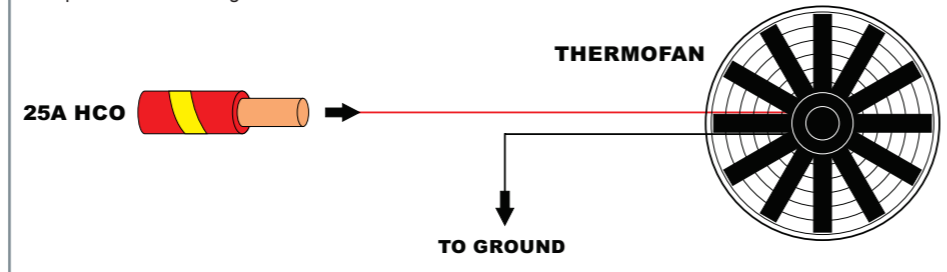

Specs:

- Automatic overcurrent protection
- Flyback protected
- 0 to 30V voltage feedback
- High side current feedback
- 100Hz max switching speed
- Capable of 0-100% duty cycle

25A High Current Outputs

The four high/low outputs on the Nexus PD16 are capable of sinking 25A to ground and driving 25A to 12V. Each output has a programmable fuse current, slow-start current and duration.

Once the electronic fuse blows the output turns off for a pre-programmed delay duration before reactivating the output. The PD16 LEDs display the output state.

25A HCOs are PWM capable and can be used for ignition power and injector power as well as to PWM thermofans and fuel pumps etc.

Specs:

- Automatic overcurrent protection
- Flyback protected
- 0 to 30V voltage feedback
- High side current feedback
- 1kHz max switching speed
- Capable of 0-100% duty cycle

Analog Voltage Inputs (AVI)

Analog Voltage Inputs accept variable voltage signals from 0V to +5V such as signals from pressure, temperature and fuel level sensors.

These inputs can also accept switched inputs that change between two different voltage levels.

The On Voltage and Off Voltage define what the thresholds are between the on and off states.

The voltage can be viewed as a channel in NSP to determine the thresholds for a switched input.

Common examples of switched inputs include A/C Request switch and intercooler spray switch.

AVIs have a software selectable 1K pull-up resistor to 5V, which can be enabled or disabled within the Setup page.

Pull-up resistors are generally enabled for temperature related sensors and switched to ground inputs.

Specs:

- 0 to 5V
- 100 samples per second
- Selectable 1k pull-up to 5V
- -10 to 30V indefinite withstand
- 1.5kHz signal frequency max
- AVI-1 has a switchable 240Ω pull up that allows direct connection with fuel level sender input.

Pull-up resistors are generally enabled for temperature related sensors and switched to ground inputs. The following configuration requires the pull-up resistor be enabled.
NOTE: AVI-1 has 1k or 240Ω pull up options for fuel level sensors.

For in-depth product overviews, step-by-step set up guides, software walk-throughs and tech tips go to the Haltech YouTube channel.

SCAN ME →

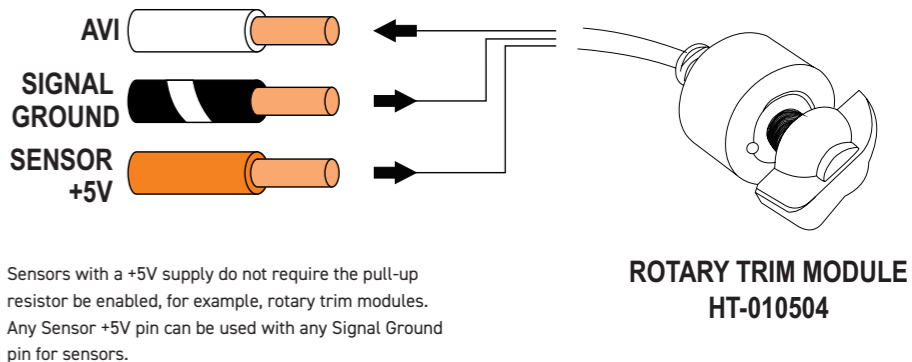
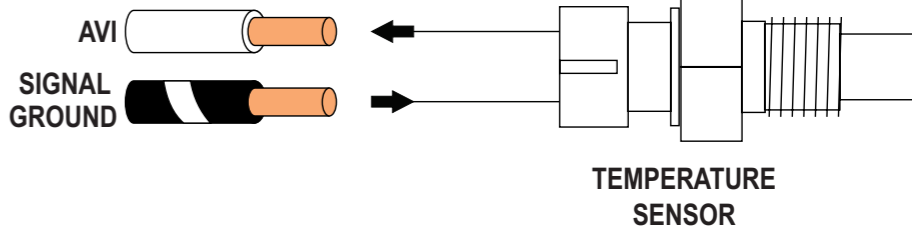

Sensors with a +5V supply do not require the pull-up resistor be enabled, for example, rotary trim modules. Any Sensor +5V pin can be used with any Signal Ground pin for sensors.

ROTARY TRIM MODULE
HT-010504

Synchronised Pulsed Inputs (SPI)

SPIs are capable of measuring the position, duty cycle, frequency or state of a signal, as well as analog voltage inputs. These inputs are suitable for sensors such as fuel composition sensors, road speed sensors and GPS Speed inputs.

SPIs are compatible with digital (hall effect or optical) and reductor (analog) based sensors, have a maximum input voltage rating of 30V and can measure up to 15KHz maximum frequency.

Specs:

- -0.5 to 12V digital input
- 0 to 5V analog input
- Selectable 1k pull-up to 5V
- -15 to 30V indefinite withstand
- 15.9kHz signal frequency max



CAN Bus

The Nexus PD16 includes a single CAN bus. The CAN Bus MUST be connected to a Haltech Elite ECU or Nexus VCU for the PD16 to operate.

Specs

- 1000 kbit/s
- Selectable 120R termination
- -40 to 40V short protection
- Supports Haltech Elite and Nexus series ECUs

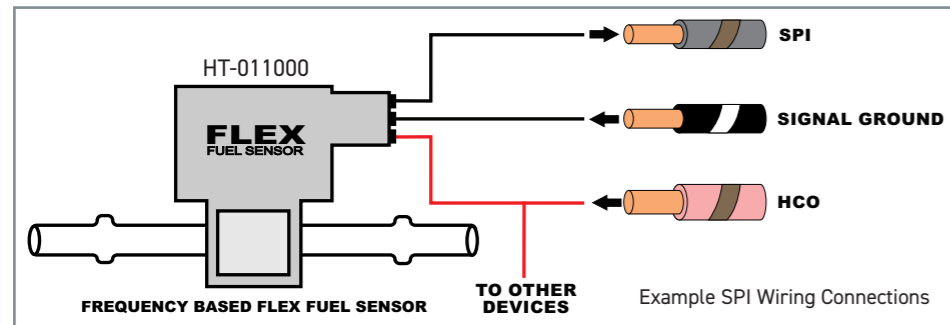

SurLok connector crimping

Separate the backshell and seal from the SurLok connector body and slide them onto the cable to be crimped. Strip 18mm (11/16") of sheathing from your 4AWG cable.

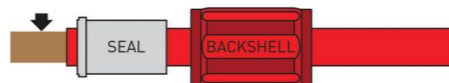

Insert your exposed cable into the SurLok connector ferrule.

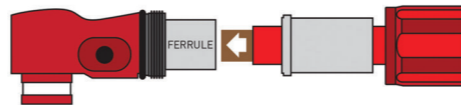

Crimp ferrule and cable together using a 25mm die. Flip cable over to ensure ferrule is crimped completely.

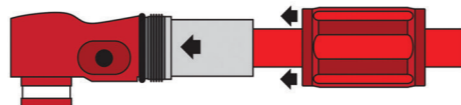
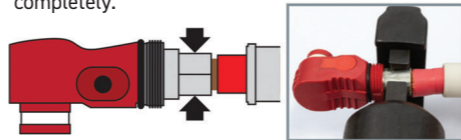

Pull the seal over the ferrule then pull the backshell, tightening it onto the SurLok connector head.



WARRANTY CERTIFICATE

At Haltech we make every effort to design and manufacture fault-free products that perform up to or above the market expectations. All our products are covered by a Limited 12 Month Warranty.

Haltech Limited Warranty

Unless specified otherwise, Haltech warrants its products to be free from defects in material or workmanship for a period of 12 months from the date of purchase.

If the Haltech product is found to be defective as mentioned above, it will be replaced or repaired if returned prepaid along with proof of purchase. Proof of purchase in the form of a copy of the original purchase invoice, receipt or bill of sale which indicates that the product is within the warranty period, must be presented to obtain warranty service.

Replacement or repair of a defective product shall constitute the sole liability of Haltech. To the extent permitted by law, the foregoing is exclusive and in lieu of all other warranties or representations, either expressed or implied, including any implied warranty of merchantability or fitness. In no event shall Haltech, be liable for special or consequential damages.

Product Returns

Please include a copy of the original purchase invoice, receipt or bill of sale along with the unused, undamaged product and its original packaging. Any product returned with missing accessory items or packaging will incur extra charges to return the item to a re-saleable condition.

All product returns must be sent via a freight method with adequate tracking, insurance and proof of delivery services. Haltech will not be held responsible for product returns lost during transit.

Returns of Products Supplied in Sealed Packaging

The sale of any sensor or accessory supplied in sealed packaging is strictly non-refundable if the sealed packaging has been opened or tampered with. This will be clearly noted on the product packaging. If you do not accept these terms please return the sensor in its original unopened packaging within 30 days for a full refund.

A sensor or accessory product may be returned after 30 days of purchase (with its sealed packaging in tact) for credit only (no refunds given) and will be subject to a 10% restocking fee.

Installation of Haltech Products

No responsibility whatsoever is accepted by Haltech for the fitment of Haltech Products. The onus is clearly on the installer to ensure that both their knowledge and the parts selected are correct for that particular application. Any damage to parts or consequential damage or costs resulting from the incorrect installation of Haltech products are totally the responsibility of the installer.

Always disconnect the battery when doing electrical work on your vehicle. Avoid sparks, open flames or use of electrical devices near flammable substances. Do not run the engine with a battery charger connected as this could damage the ECU and other electrical equipment.

Do not overcharge the battery or reverse the polarity of the battery or any charging unit. Disconnect the Haltech ECU from the electrical system whenever doing any welding on the vehicle by unplugging the wiring harness connector from the ECU.

After completing the ECU installation, make sure there is no wiring left un-insulated. Uninsulated wiring can cause sparks, short circuits and in some cases fire. Before attempting to run the engine ensure there are no leaks in the fuel system.

All fuel system components and wiring should be mounted away from heat sources, shielded if necessary and well ventilated. Always ensure that you follow workshop safety procedures. If you're working underneath a jacked-up car, always use safety stands!

Haltech Off-Road Usage Policy

In many states it is unlawful to tamper with your vehicle's emissions equipment. Haltech products are designed and sold for sanctioned off-road/competition non-emissions controlled vehicles only and may never be used on a public road or highway.

Using Haltech products for street/road use on public roads or highways is prohibited by law unless a specific regulatory exemption exists (more information can be found on the SEMA Action Network website www.semanet.com/emissions for state by state details in the USA).

It is the responsibility of the installer and/or user of this product to ensure compliance with all applicable local and federal laws and regulations. Please check with your local vehicle authority before purchasing, using or installing any Haltech product.



Haltech Australia

17 Durian Place,
Wetherill Park NSW 2164
Australia
Phone: +61 2 9729 0999
Email: aus@haltech.com

Haltech New Zealand

Grey Lynn Auckland, NZ 1021
Phone: 09 887 0616
Email: nz@haltech.com

Haltech USA East

750 Miles Point Way,
Lexington, KY USA 40510
Phone: (888) 298 8116
Email: usa@haltech.com

Haltech USA West

Race Winning Brands,
10800 Valley View Street,
Cypress, CA 90630
Phone: (888) 298 8116
Email: usa@haltech.com

Haltech UK

Unit 1, Miras Business Estate,
Keys Park Road, Hednesford,
WS12 2FS
Phone: +44 121 285 6650
Email: uk@haltech.com

Haltech Europe

Ottogasse 2A,
2333 Leopoldsdorf, Austria
Phone: +43 720 883968
Email: europe@haltech.com

